

| REV | DESCRIPTION                         | DATE     |
|-----|-------------------------------------|----------|
| A   | CORRECTED RACK MOUNT BRACKET DETAIL | 10/11/01 |
|     |                                     |          |
|     |                                     |          |
|     |                                     |          |

## NOTES

**MATERIAL** TOP & BOTTOM 0.062" STEEL, SIDES, FRONT, REAR & HORIZONTAL SUPPORTS 0.125" ALUMINUM, DIMENSIONS ARE TAKEN WITH THE PAINTED SURFACE

**FINISH** TOP, BOTTOM & SIDE PANELS, TEXTURED BLACK, FRONT/REAR PANELS ON SMOOTH BLACK, ONE CONTEMPRA GRAY (RAL 7032), ALL POWDER PAINT.

## FRONT VIEW

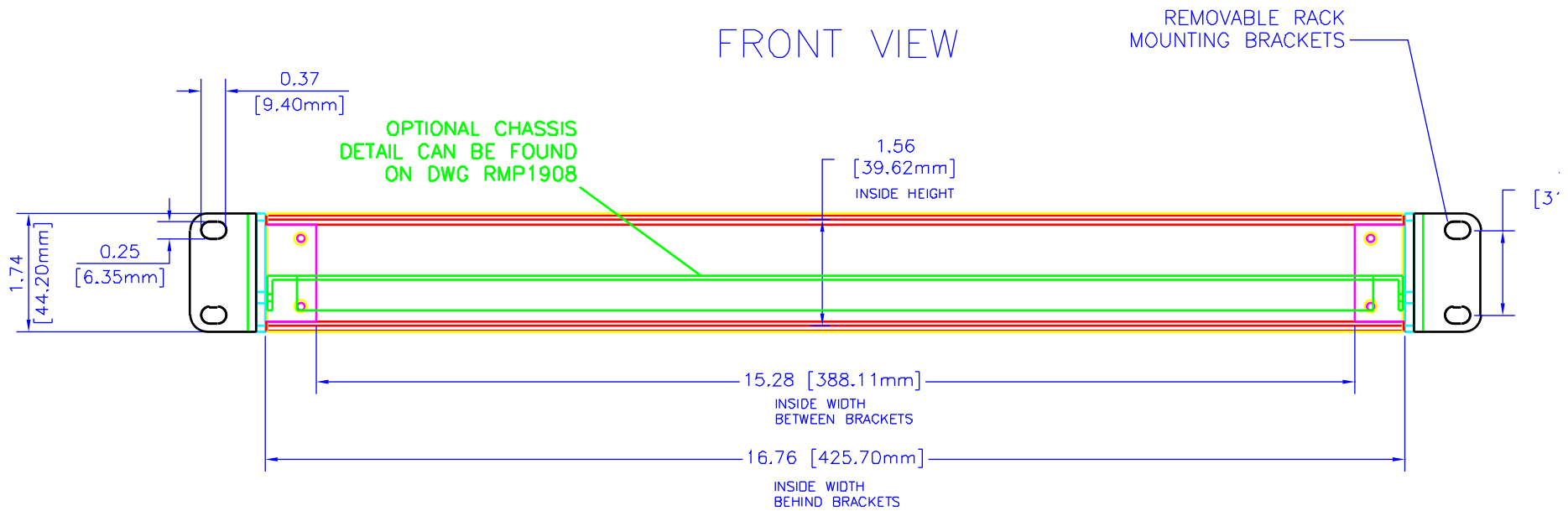

UNLESS OTHERWISE SPECIFIED  
DIMENSIONS ARE IN INCHES

|        |            |
|--------|------------|
| X      | +/- .1     |
| XX     | +/- .02    |
| XXX    | +/- .015   |
| DIPS   | +/- .008   |
| ANGLES | +/- 5 DEG. |

**NOTICE**  
HAMMOND MANUFACTURING PROPRIETARY RIGHTS TO THE MATERIAL ON THIS DRAWING IS HEREBY  
INTENDED TO BE USED AS A REFERENCE FOR  
ENGINEERING INFORMATION ONLY. THIS  
INFORMATION MAY NOT BE USED TO  
MANUFACTURE PRODUCTS WITHOUT WRITTEN  
PERMISSION FROM HAMMOND MANUFACTURING.



**HAMMOND  
MANUFACTURING**

WEB: [WWW.HAMMONDMFG.COM](http://WWW.HAMMONDMFG.COM)

|             |     |                                       |          |
|-------------|-----|---------------------------------------|----------|
| TITLE       |     | HAMMOND RMCV SERIES<br>RACK ENCLOSURE |          |
| DRAWN BY    | MJM | DATE                                  | 10/04/01 |
| SCALE       |     | PAGE                                  | 1 OF 3   |
| PART NUMBER |     | RMCV19018                             |          |

# SIDE VIEW

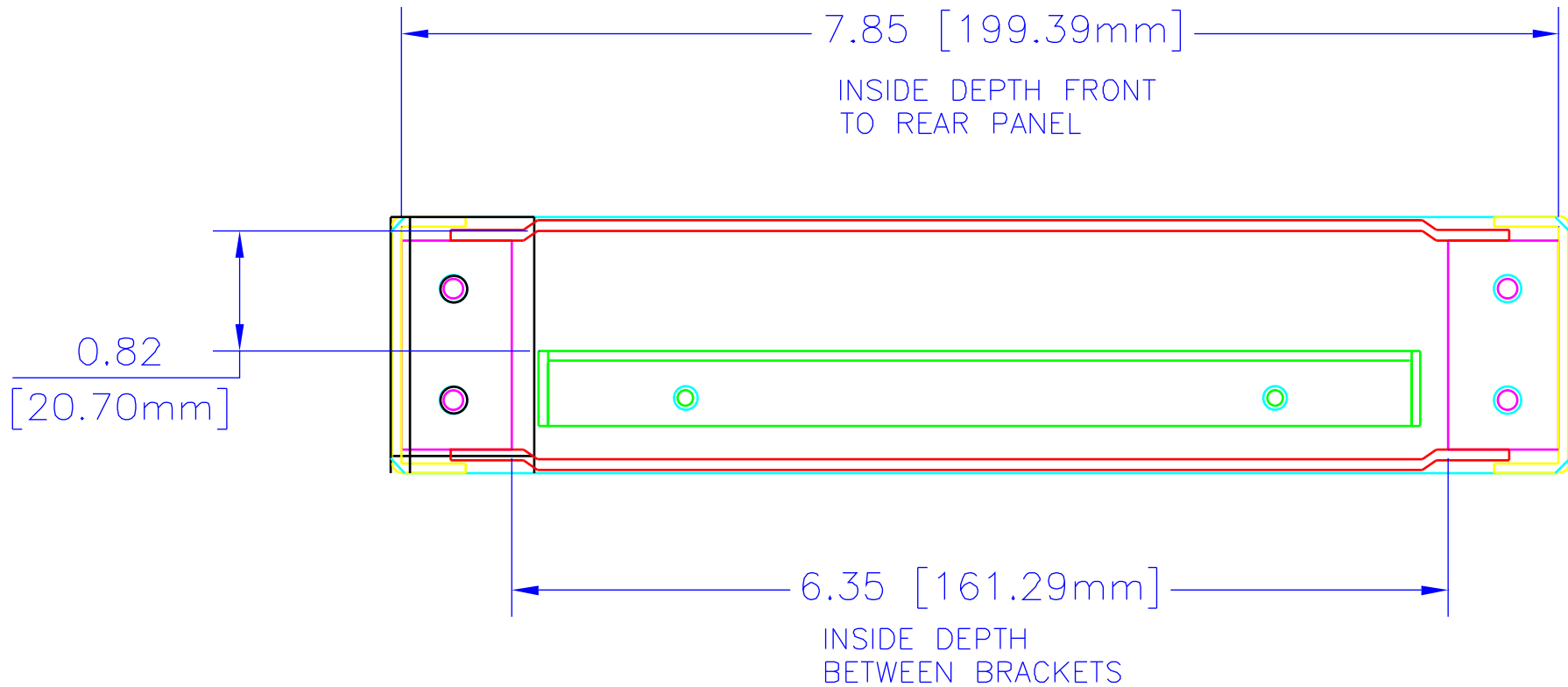

UNLESS OTHERWISE SPECIFIED  
DIMENSIONS ARE IN INCHES

|        |            |
|--------|------------|
| x      | +/- .1     |
| xx     | +/- .02    |
| xxx    | +/- .015   |
| xxxx   | +/- .008   |
| ANGLES | +/- 5 DEG. |

NOTICE:  
HAMMOND MANUFACTURING RESERVES THE RIGHT TO CHANGE THE MATERIAL OR THIS DRAWING AT ANY TIME WITHOUT NOTICE. THIS INFORMATION IS FOR ENGINEERING INFORMATION ONLY. THIS INFORMATION MAY NOT BE USED TO MANUFACTURE PRODUCTS WITHOUT WRITTEN PERMISSION FROM HAMMOND MANUFACTURING.



**HAMMOND  
MANUFACTURING**

WEB: [WWW.HAMMONDMFG.COM](http://WWW.HAMMONDMFG.COM)

|             |           |                                       |          |
|-------------|-----------|---------------------------------------|----------|
| TITLE       |           | HAMMOND RMCV SERIES<br>RACK ENCLOSURE |          |
| DRAWN BY    | MJM       | DATE                                  | 10/04/01 |
| SCALE       |           | PAGE                                  | 2 OF 3   |
| PART NUMBER | RMCV19018 |                                       |          |

# TOP VIEW

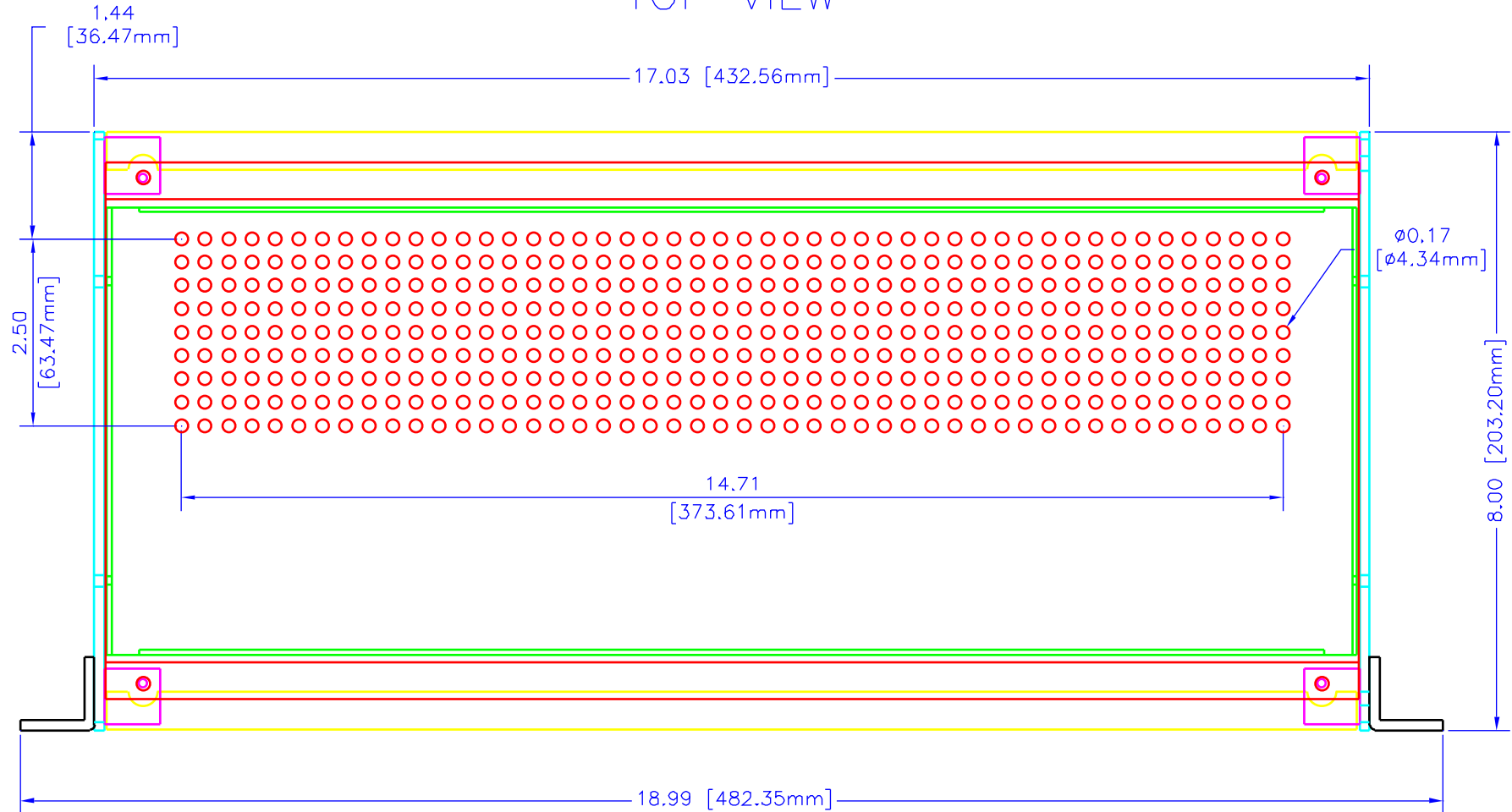

UNLESS OTHERWISE SPECIFIED  
DIMENSIONS ARE IN INCHES.

|        |            |
|--------|------------|
| X      | +/- .1     |
| XX     | +/- .02    |
| XXX    | +/- .015   |
| DITS   | +/- .008   |
| ANGLES | +/- 5 DEG. |

NOTICE  
HAMMOND IS A PROPRIETARY RIGHTS TO  
THE MATERIAL OF THIS DRAWING IT IS  
INTENDED TO BE USED AS A REFERENCE FOR  
ENGINEERING INFORMATION ONLY. THE  
INFORMATION MAY NOT BE USED TO  
MANUFACTURE PRODUCTS WITHOUT WRITTEN  
PERMISSION FROM HAMMOND MANUFACTURING.



**HAMMOND  
MANUFACTURING**

WEB: [WWW.HAMMONDMFG.COM](http://WWW.HAMMONDMFG.COM)

TITLE  
HAMMOND RMCV SERIES  
RACK ENCLOSURE

DRAWN BY MJM DATE 10/04/01

SCALE PAGE 3 OF 3

PART NUMBER  
RMCV19018